



SERIES- Ø 125mm

标准型 警示灯 Standard Size Warning/Signal Light



S125L | LED 长亮/闪亮 警示灯

LED Steady/Flashing Light



S125L

采用散光效果优秀的灯罩提高可见度

- 高亮度 LED 长亮/闪亮型
 - 内装长亮/闪亮选择开关
 - 采用使用寿命为半永久性的发光二极管, 适用于震动及冲击较大的设备
 - 内部可以装蜂鸣器。音量: Max.90dB/m * 可以定做2音蜂鸣器型
 - 材质: 灯罩-AS, 底座-ABS, 反射镜-耐热性 ABS
 - 技术认证: CE
 - 保护等级: IP44
- Product of steady/flashing, high-brightness LED type
 - Having the built-in switch for steady/flashing selection
 - Semi-permanent in the lifespan of light source and suitable for machines having lots of vibration and impact
 - Option: buzzer applicable. Volume: Max.90dB/m
 - Material: Lens-AS, Body-ABS, Reflector-Heat resisting ABS
 - Certificate: CE
 - Protection class: IP44

型号 Model	电压 Rated Voltage	电流 Current	重量 Weight	闪光次数 Flashes Per Min.	颜色 Color
S125L	DC12V	0.300A	0.30Kg	60~80	■ 红-R ■ 黄-A ■ 绿-G ■ 蓝-B
	DC24V	0.200A	0.30Kg		
	AC110V	0.060A	0.52Kg		
	AC220V	0.030A	0.52Kg		

外形图 (External view drawing)

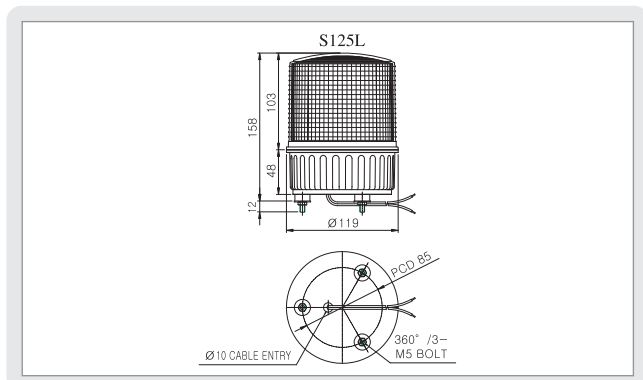

- 电源线 引出型 UL1015-NO.18(0.75sq)x2C 400mm
- DC 产品: 黑色线表示负极(-)
- Power line out from the product UL1015-NO.18(0.75sq)x2C 400mm
- The black line of DC product is negative(-)

S125 SERIES 产品指定 (Order Specification)

• 内部可以装蜂鸣器的产品 (Buzzer Applicable)

S125R - (BZ) - 220 - R

型号 (Model)	蜂鸣器 (Buzzer)	电压 (Voltage)	颜色 (Color)
· S125R	· 无指定(None)	· 12-DC12V	■ R-红(Red)
· S125U	Without Buzzer	· 24-DC24V	■ A-黄(Amber)
· S125L	· BZ指定(Order)	· 110-AC110V	■ G-绿(Green)
· S125LR	With Buzzer	· 220-AC220V	■ B-蓝(Blue)
· S125RLR			
· S125E			
· S125M			
· S125MLR			

• 内部不可以装蜂鸣器的产品 (Buzzer Inapplicable)

S125SM - 24 - A

型号 (Model)	电压 (Voltage)	颜色 (Color)
· S125S	· 12-DC12V	■ R-红(Red)
· S125HS	· 24-DC24V	■ A-黄(Amber)
· S125SM		■ G-绿(Green)
· S125HSM		■ B-蓝(Blue)

- ※ 可以定做超高度HS型产品。
- ※ High brightness strobe HS type is custom-made.

WARNING / SIGNAL LIGHT